

PARUL UNIVERSITY
FACULTY OF ENGINEERING & TECHNOLOGY
B.Tech. winter 2019 - 20 Examination

Semester: 5
 Subject Code: 03101304
 Subject Name: Aircraft Structures-II

Date: 05/12/2019
 Time: 10:30am to 1:00pm
 Total Marks: 60

Instructions:

1. All questions are compulsory.
2. Figures to the right indicate full marks.
3. Make suitable assumptions wherever necessary.
4. Start new question on new page.

Q.1 Short Type Questions (each of one mark)**(15)**

- 1) In case of rectangular section

(a) $\tau_{max} = \frac{1}{2} \tau_{mean}$

(b) $\tau_{max} = \frac{2}{3} \tau_{mean}$

(c) $\tau_{max} = \frac{3}{2} \tau_{mean}$

(d) $\tau_{max} = \frac{4}{3} \tau_{mean}$

- 2) Shear flow in any cross-section

- (a) constant
- (b) depends on the thickness
- (c) depends on the cross-sectional area
- (d) none of the above

- 3) In case of a circular section

(a) $\tau_{max} = \frac{1}{2} \tau_{mean}$

(b) $\tau_{max} = \frac{2}{3} \tau_{mean}$

(c) $\tau_{max} = \frac{3}{2} \tau_{mean}$

(d) $\tau_{max} = \frac{4}{3} \tau_{mean}$

- 4) A wing spar (I-section) subjected to transverse shear force (S), the maximum shear stress(
- τ
-) is developed

- (a) at the Centre of the web
- (b) at the top edge of the top flange
- (c) at the bottom edge of the top flange
- (d) at the bottom edge of the bottom flange

- 5) In I-section of a beam subjected to bending moment(M),the maximum bending stress(
- σ
-) is developed

- (a) at the Centre of the web
- (b) at the top edge of the top flange
- (c) at the bottom edge of the top flange
- (d) at the top edge of the bottom flange

- 6) What is the general cross-section required for the spar, for such c/s draw the shear flow.

- 7) Define buckling.

- 8) Write the Rankine formula and its application in columns.

- 9) Write the condition for plane stress

- 10) Write the condition for plane strain

- 11) The expression for checking the determinacy of the Truss structure is _____

- 12) The flanges and web of the I-section beams carry _____ and _____ loads respectively.

- 13) The expression of normal stress along the thickness for the case of plane strain is given as _____.

- 14) The hollow circular sections are preferable when compared to solid circular section because of high _____.

- 15) The aircraft components are generally subjected to the _____, _____, _____ and _____.

Q.2 Answer the following questions. (Attempt any three)

(15)

1. Derive the compatibility equations for a three dimensional element.
2. Calculate the shear flow distribution in the channel section shown in Fig. below produced by a vertical shear load of 4.8 kN acting through its shear centre. Assume that the walls of the section are only effective in resisting shear stresses while the booms, each of area 300mm², carry all the direct stresses.

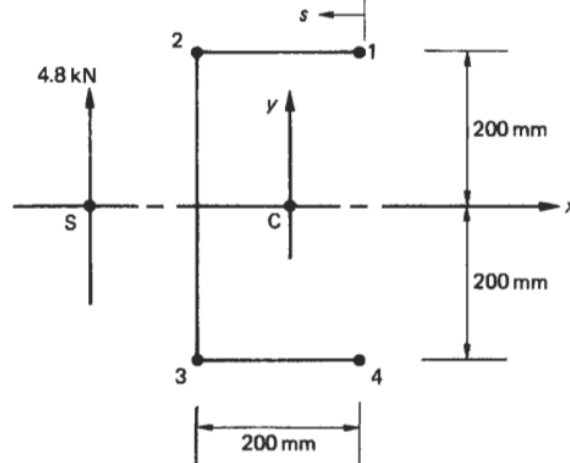

3. Derive the Bradth-Batho formula for a wing box under torsional load, which is under torsional moment T and having A_m, q are median cross-section area and shear flow respectively.
4. Explain shear center and its properties. How the shear center is different from the centroid.

Q.3A) Find the shear flow distribution in a thin walled channel section (C-Section), whose thickness is 't', height 'h' and Flange width 'b' subjected to vertical shear load through shear centre. **(07)**

Q.3B) Derive the critical buckling load for column having its length (ℓ) hinged on both the ends. **(08)**

OR

Q.3B) Derive the critical or crippling buckling load for column having its length (ℓ) fixed on both the ends. **(08)**

Q.4A) Part of a wing section is in the form of the two-cell box shown in Fig. as shown below in which the vertical spars are connected to the wing skin through angle sections all having a cross-sectional area of 300mm². Idealize the section into an arrangement of direct stress carrying booms and shear stress only carrying panels suitable for resisting bending moments in a vertical plane. Position the booms at the spar/skin junctions.. **(07)**

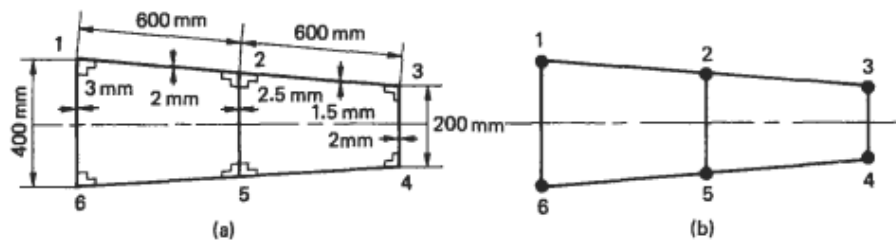

OR

- Q.4A)** A beam having the cross section shown in Figure is subjected to a bending moment of 1500 Nm in a vertical plane. Calculate the maximum direct stress due to bending stating the point at which it acts. (07)

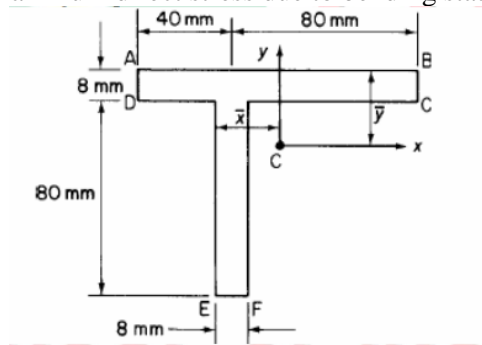

- Q.4B)** A two-cell tube as shown in the figure is subjected to a torque of 10 kN-m. Draw the Shear flow distribution. Take modulus of rigidity of the material as 83 kN/mm². (08)

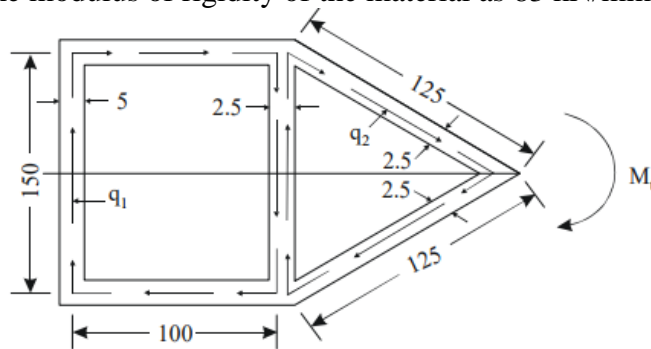

All dimensions in mm