

PARUL UNIVERSITY
FACULTY OF ENGINEERING & TECHNOLOGY
B.Tech. Summer 2018 - 19 Examination

Semester: 3
Subject Code: 03191202
Subject Name: Discrete Mathematics

Date: 30/05/2019
Time: 02:00 pm to 04:30 pm
Total Marks: 60

Instructions:

1. All questions are compulsory.
2. Figures to the right indicate full marks.
3. Make suitable assumptions wherever necessary.
4. Start new question on new page.

Q.1 Do as directed:

(15)

1. How many relations are possible from A to B if $A = \{1,2\}$ and $B = \{a, b, c\}$?
2. Draw a circuit that produces $\bar{x}\bar{y}$ output when x and y are input.
3. What is the order of the graph S_4 ?
4. The bitwise OR of each of the following pair of bit strings: 1101 1011 1011;1001 0110 1010 will be ____.
5. If a relation R satisfies reflexive, symmetric and transitive property then the relation is called ____ relation.
6. How many different bit strings of length 4 are there?
7. The complement of the function $F(x, y, z) = (xy) + (\bar{x}z) + (y\bar{z})$ is _____.
8. If $G = \{a, a^2, a^3, a^4, a^5, a^6 = e\}$ is a group under multiplication, then $o(a^3) =$ _____
9. The relation R on $A = \{0,1,2,3,4\}$ is defined by the rule $(a,b) \in R$, if 2 divides $a - b$. List the elements of R .
10. The degrees of a pendant vertex is _____.
11. Draw $K_{4,3}$ and name the vertices as per your choice.
12. How many edges are there in a graph with 10 vertices each of degree three?
 (a) 30 (b) 20 (c) 15 (d) 10
13. Which of following sentence is not propositions?
 (a) This problem is hard to be solved. (b) Will you be able to solve it?
 (c) It is solvable only if $x = 2$. (d) It is not a valid question.
14. Which of the undirected graphs in the figure have an Euler circuit?



15. The following graph is _____ .

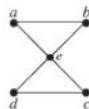

- (a) Complete bipartite (b) Complete Graph (c) Simple Graph (d) None of them

Q.2 Answer the following questions. (Attempt any three)

(15)

A) If $*$ is defined on \mathbb{Z} such that $a * b = a + b + 2 \quad \forall a, b \in \mathbb{Z}$.

Prove that $(\mathbb{Z}, *)$ is an abelian group

B) Use the method of contradiction to prove that $\sqrt{2}$ an irrational number.

C) Define spanning tree.

Use Kruskal's algorithm to find minimum spanning tree for the following graph.

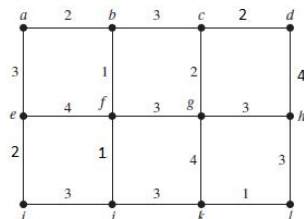

D) (i) Find the number of vertices, number of edges, and degree of each vertex in the following Undirected graph. Identify all isolated and pendant vertices. Verify Handshaking Theorem

(3+2)

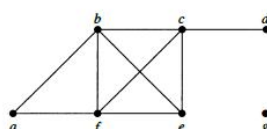

(ii) Find the centre of the following graph.

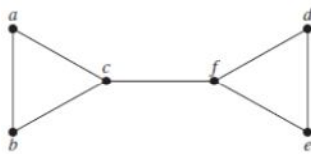

Q.3 A) Determine whether the graphs shown in the figure are isomorphic. (07)

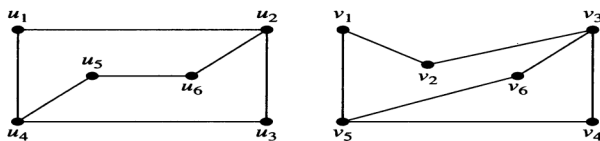

B) Consider the following elements of S_5 . (08)

$$\alpha = \begin{pmatrix} 1 & 2 & 3 & 4 & 5 \\ 2 & 3 & 1 & 4 & 5 \end{pmatrix}, \beta = \begin{pmatrix} 1 & 2 & 3 & 4 & 5 \\ 1 & 2 & 3 & 5 & 4 \end{pmatrix}, \gamma = \begin{pmatrix} 1 & 2 & 3 & 4 & 5 \\ 5 & 4 & 3 & 1 & 2 \end{pmatrix}, \delta = \begin{pmatrix} 1 & 2 & 3 & 4 & 5 \\ 3 & 2 & 1 & 5 & 4 \end{pmatrix}$$

- (i) Find $\alpha\beta\delta\gamma$.
- (ii) Find γ^{-1} .
- (iii) find the order of α
- (iv) Solve the equation $\delta x = \beta$.

OR

B) i) Assuming that repetitions are not permitted, find: (5+3)

1. How many four digit numbers can be formed from the five digits 1, 2, 3, 5, 7 ?
2. How many numbers in part 1 are less than 4000?
3. How many numbers in part 1 are odd?
4. How many numbers in part 1 are multiple of 5?
5. How many numbers in part 1 contain both the digits 3 and 5 ?

ii) Find Boolean Expression that represent following circuit:

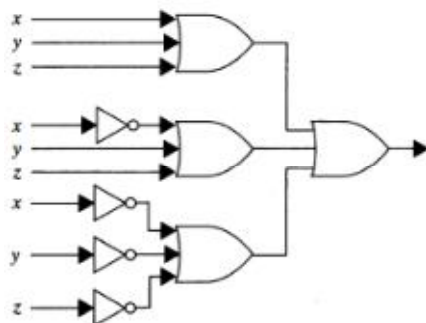

Q.4 A) Use Dijkstra's algorithm to find the length of a shortest path between the vertices a and z in the weighted graph displayed in the figure (07)

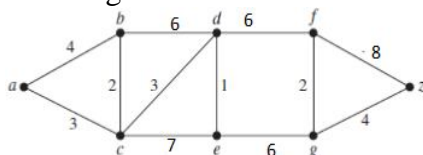

OR

A) Find the matrix representing the relation $S \circ R$, hence draw the digraph of $S \circ R$ where the matrices representing R and S are (07)

$$M_R = \begin{bmatrix} 1 & 0 & 1 \\ 1 & 1 & 0 \\ 0 & 0 & 1 \end{bmatrix} \text{ and } M_S = \begin{bmatrix} 1 & 1 & 0 \\ 0 & 0 & 1 \\ 1 & 0 & 0 \end{bmatrix}$$

Check whether the relation $S \circ R$ is reflexive, symmetric or anti-symmetric

B) i) Determine whether the relation R on the set of natural numbers is reflexive, symmetric, anti-symmetric, and/or transitive, where $(a,b) \in R$ if and only if $ab \geq 1$. (5+3)

And hence check it is an equivalence relation or a partial ordering relation.

ii) By using table, verify the following Boolean Identity $(x y) + (x z) = x (y + z)$