

**PARUL UNIVERSITY**  
**FACULTY OF ENGINEERING & TECHNOLOGY**  
**B.Tech. Summer 2017 - 18 Examination**

**Semester: 1, 2**  
**Subject Code: 03109101**  
**Subject Name: Engineering Graphics**

**Date: 05/06/2018**  
**Time: 2:00PM TO 04:30PM**  
**Total Marks: 60**

**Instructions:**

1. All questions are compulsory.
2. Figures to the right indicate full marks.
3. Make suitable assumptions wherever necessary.
4. Start new question on new page.

**Q.1 Objective Type Questions -****(15)**

1. For the third angle projection method, which of the following is correct?  
 (a) Observer - Object - Plane (b) Observer - Plane - Object (c) both (d) None of above.
2. If an object lies in third quadrant, its position with respect to reference planes will be  
 (a) in front of V.P., above H.P. (b) behind V.P., above H.P.  
 (c) behind V.P., below H.P. (d) in front of V.P., below H.P.
3. The included angle of a hexagon is  
 (a) 30° (b) 60° (c) 120° (d) 150°
4. Length of a line 'L' in isometric drawing or view will be  
 (a) 0.707 L (b) 0.815 L (c) 0.866 L (d) equal to length L
5. When a cone is cut by a plane perpendicular to base passing through the apex "the shape of section obtained is.  
 (a) ellipse (b) parabola (c) hyperbola (d) triangle
6. Explain the term HCP.
7. Explain the term VCP.
8. Explain the term AIP.
9. Explain the term AVP.
10. Explain Unidirectional Dimensioning system.
11. Explain Aligned Dimensioning system.
12. Define Eccentricity.
13. Define Representative Fraction.
14. Mark the projections of the following points on a common reference line: A, 30 mm behind the VP and 20 mm below the HP.
15. Mark the projections of the following points on a common reference line: Q, 50 mm in front of VP and 30 mm above the HP.

**Q.2 Answer the following questions. (Attempt any three)****(15)**

- A) The major axis and the minor axis of Ellipse are 120 mm and 80 mm respectively. Construct an ellipse by Concentric circle method.
- B) Explain criteria for getting curves of conic sections.
- C) Construct a Square, a regular Pentagon, a regular Hexagon, Heptagon and Octagon in the same figure taking AB = 50 mm as a common side. (UNIVERSAL METHOD)
- D) Explain the difference between 1<sup>st</sup> angle & 3<sup>rd</sup> angle orthographic projections.

**Q.3 A) A pentagon plate, side 40mm is resting on H.P. on one of its side. The plate is inclined to H.P. by 45° . Draw its projections when the edge which is on H.P makes 30° to V.P. (07)**

- B) A Room measure 10 m long, 8 m wide and 5 m high. A bulb hangs in the center of the ceiling and thin straight wire connects the bulb to a switch which is kept in the one of the 8m x 5m wall at 2 m above the floor and 3m away from the adjacent wall. Draw the projection and find out true length of the wire. **(08)**

**OR**

- B) A square pyramid of base side 25mm and axis height 60mm rests on the HP on its base with the base edges equally inclined to the VP. It is cut by a plane perpendicular to the VP and inclined at 30° to the HP meeting at 21mm above the base on the axis. Draw the sectional top view and development of surfaces. **(08)**

**Q.4 A) A right circular cone diameter of base 60 mm and height 60 mm rests on ground on its base. A bee starts from the Left hand of its base rim and moves around the surface of the cone and finally come backs to the starting point. Find the shortest path the bee should take in covering the distance along the surface of the cone. Also show the path in front and top view. (07)**

OR

A) The figure no.1 shows orthographic view of an object. Draw isometric view of the object and give dimensions. (07)

B) Draw the ELEVATION and PLAN using First angle projection method: Figure.no.2 (08)

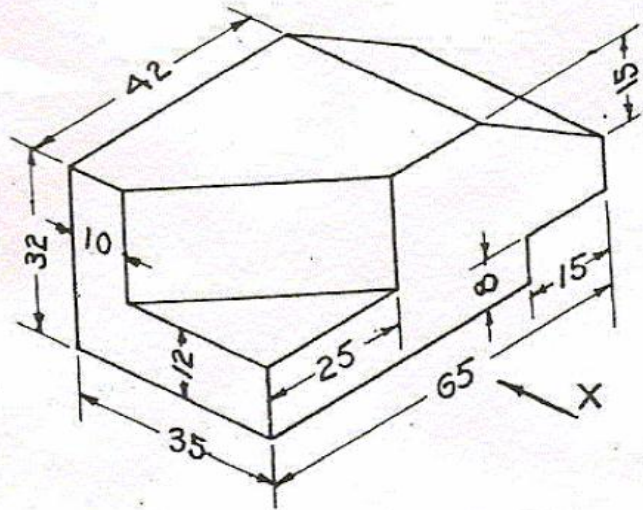

FIGURE NO.2

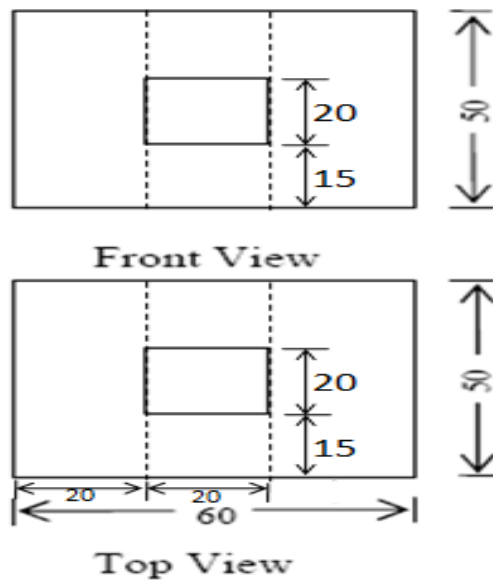

FIGURE NO.1