

PARUL UNIVERSITY
FACULTY OF ENGINEERING & TECHNOLOGY
B.Tech. Summer 2018 - 19 Examination

Semester: 6

Subject Code: 03109351

Subject Name: Machine Design - I

Date: 11/05/2019

Time: 10:30am To 01:00pm

Total Marks: 60

Instructions:

1. All questions are compulsory.
2. Figures to the right indicate full marks.
3. Make suitable assumptions wherever necessary.
4. Start new question on new page.

Q.1 Objective Type Questions - (Fill in the blanks, one word answer, (All are compulsory) (Each of one mark) (15)

1. 18/8 steel contains

(a) 18 % nickel and 8 % chromium	(b) 18 % chromium and 8 % nickel
(c) 18 % nickel and 8 % Vanadium	(d) 18 % vanadium and 8 % nickel
2. If Z = Absolute viscosity of the lubricant in kg/m-s, N = speed of the journal in rpm, and p = bearing pressure in N/mm^2 , then the bearing characteristic number is

(a) $\frac{ZN}{P}$	(b) $\frac{ZP}{N}$	(c) $\frac{Z}{PN}$	(d) $\frac{PN}{Z}$
--------------------	--------------------	--------------------	--------------------
3. Resilience is the ability to absorb energy within

(a) Plastic range	(b) Elastic range	(c) Elastic and plastic range	(d) Elasto-plastic range
-------------------	-------------------	-------------------------------	--------------------------
4. The diameter of shaft of bearing for bearing no 6315

(a) 25mm	(b) 30mm	(c) 50mm	(d) 75mm
----------	----------	----------	----------
5. Ball bearing are usually made from

(a) Low carbon steel	(b) High carbon steel
(c) Medium carbon steel	(d) High speed steel
6. A pressure vessel is said to be a thin cylindrical shell, if the ratio of the wall thickness of the shell to its diameter is.....

(a) equal to 1/10	(b) less than 1/10	(c) more than 1/10	(d) none of these
-------------------	--------------------	--------------------	-------------------
7. When two concentric coil springs made of the same material, having same length compressed equally by an axial load, the load shared by the two springs will be.....to the square of the diameters of the wires of the two springs.

(a) directly proportional	(b) inversely proportional	(c) equal to
---------------------------	----------------------------	--------------
8. The tension in the slack side of the belt is..... the tension in the tight side of the belt.

(a) equal to	(b) less than	(c) greater than
--------------	---------------	------------------
9. The longitudinal stress is.....of the circumferential stress in case of thin pressure vessel.

(a) one-half	(b) two-third	(c) three-fourth
--------------	---------------	------------------
10. The speed of the sprocket reduces as the chain pitch.....for a given number of teeth.

(a) increases	(b) decreases
---------------	---------------
11. What are the types of stresses in thin cylinder?
12. What is standardization?
13. What is Wahl factor? Why is it used?
14. What is mean by ply of belt?
15. What is a sliding contact bearing?

Q.2 Answer the following questions. (Attempt any three) (15)

- A) Explain the following terms with neat sketch.
- | | | | | |
|----------------|-----------------|----------------|----------|-----------------|
| 1. Spring rate | 2. Spring index | 3. Free length | 4. Pitch | 5. Solid length |
|----------------|-----------------|----------------|----------|-----------------|
- B) Explain aesthetic and ergonomic considerations in Design,
 C) Explain types of spring with neat sketch.
 D) Explain types of belt with neat sketch

Q.3 A) Design a close coiled helical compression spring for a service load ranging from 2250 N to 2750 N. The axial deflection of the spring for the load range is 6 mm. Assume a spring index of 5. The permissible shear stress intensity is 420 MPa and modulus of rigidity, $G = 84 \text{ kN/mm}^2$. (07)

Neglect the effect of stress concentration. Draw a fully dimensioned sketch of the spring showing details of the finish of the end coils. Assume squared and ground ends.

B) Explain Stribeck's equation with neat sketch. (08)

OR

B) The layout of a leather belt drive transmitting 15kw of power is shown in fig. The centre distance between the pulleys is twice the diameter of the bigger pulley. The belt should operate at a velocity of 20 m/s approximately and the stresses in the belt should not exceed 2.25 N/mm². The density of leather is 0.95 g/cc and the coefficient of friction is 0.35. The thickness of the belt is 5mm. Calculate (08)

1. The diameter of pulleys
2. The length and width of the belt; and
3. The belt tensions.

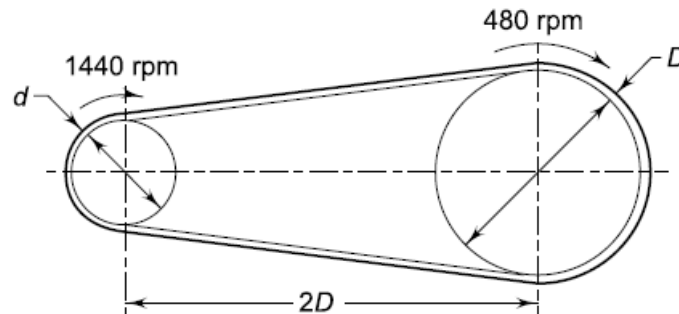

Q.4 A) A transmission shaft rotating at 720 rpm and transmitting power from the pulley P to the spur gear G is shown in fig. The belt tensions and the gear tooth forces are as follows: $P_1 = 498$ N, $P_2 = 166$ N, $P_t = 497$ N, $P_r = 181$ N. (07)

The weight of the pulley is 100 N. The diameter of the shaft at bearings B1 and B2 is 10 mm and 20 mm respectively. The load factor is 2.5 and the expected life for 90% of the bearings is 8000 h. Select single-row deep groove ball bearings at B₁ and B₂.

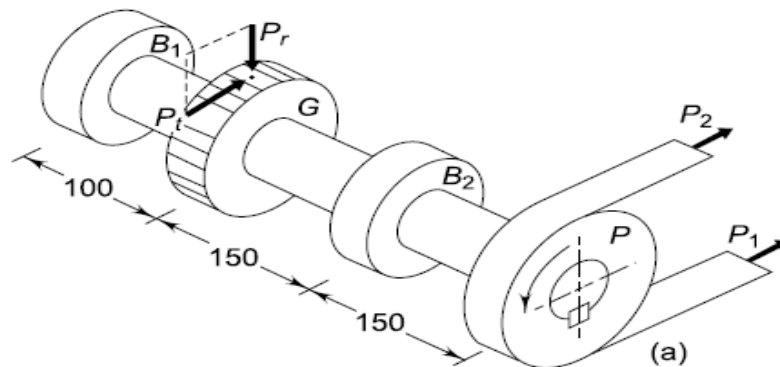

OR

A) Explain design of chain drive procedure with neat sketch. (07)

B) Explain circumferential stress and Longitudinal stress with neat sketch for thin pressure vessel. (08)